

## Motor reactor MR3 400/48

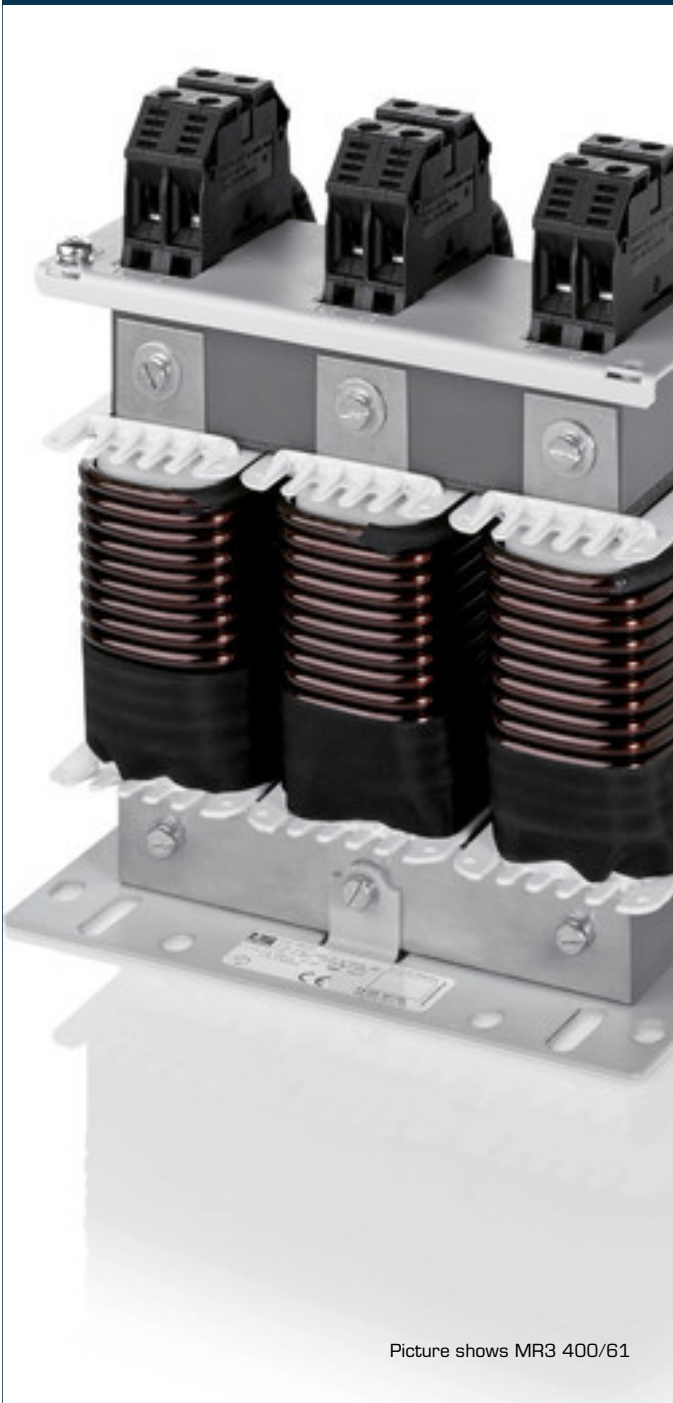

Picture shows MR3 400/61

### Advantages

High damping of edge steepness
High damping of inverter switching frequency
Reduction of leakage current at low construction volumes
Long shielded cable lengths possible
High efficiency
Very good corrosion protection and low noise due to vacuum impregnation

### Applications

Motor reactor for the limitation of the voltage peaks damaging to the motor insulation (dv/dt).

### Standards

Output reactor for frequency converter  
DIN EN 61558-2-20, IEC 61558-2-20

### Approvals





# Motor reactor MR3 400/48

Type		MR3 400/48
Electrical data	Operating data	
	Rated voltage	3 x 400 Vac
	Voltage range	3 x 0 - 500 Vac
	Rated current	48 A
	for motor rated output approx.	29.50 HP
	Inductance	0.13 mH
	Rated frequency	0 - 50 Hz
	Switching frequency	3 - 8 kHz
	Approvals	
	Approvals	cURus
	Environment	
	Ambient temperature max.	104.0 °F
	Safety and protection	
	Type	Open type
Protection index	IP 00	
Safety class (prepared)	I	
Test voltage	4000 Vac, 50 Hz	
Insulation class	VDE=F, UL=class 130	
Order numbers		
Order Number	MR3 400/48	

Type		MR3 400/48
Mechanical data	Terminal and mounting	
	Terminals phase	Screw clamp, 16 mm <sup>2</sup>
	Connection type	Bolt, M5
	Fixing method	Fixing rail
	Fixing screws	M5
Measures and weights		
Weight	14.33 lbs	

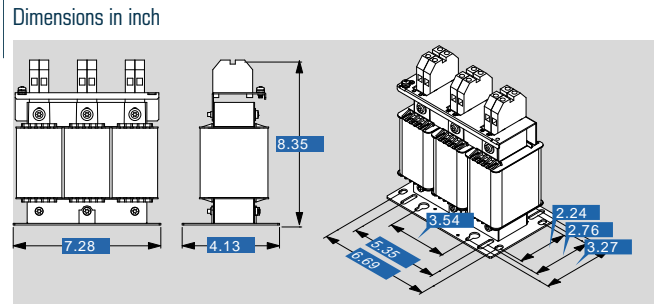

Subject to change.